

FLEXIBLE SCREW CONVEYOR

Reduce Operator Handling of Dry Material



- **Designed to handle bulk dry powders and granular materials.**
- **Able to deliver bulk product at desired rate and elevation.**
- **Multiple motor mounting methods available.**
- **Designed for continuous or intermitted operation.**
- **NEMA 4X controls are standard**
- **Remote start/stop capability**
- **Available in 304L and 316L stainless steel.**
- **Capable of receiving super sacks or manual bag unloading hoppers.**
- **Tube Constructed of UHMW.**

Custom models and options available, consult factory.

**Contact us at
4225 NE Port Dr.
Lee's Summit, MO 64064
816-795-6333 phone
816-795-6030 fax
www.ipm-sys.com**

The IPM Flexible Screw Conveyor is the perfect solution to retro fit applications. By utilizing the flex conveyor with our bulk bag unloader or manual bag unloading station, you can easily configure a system to meet difficult height requirements.

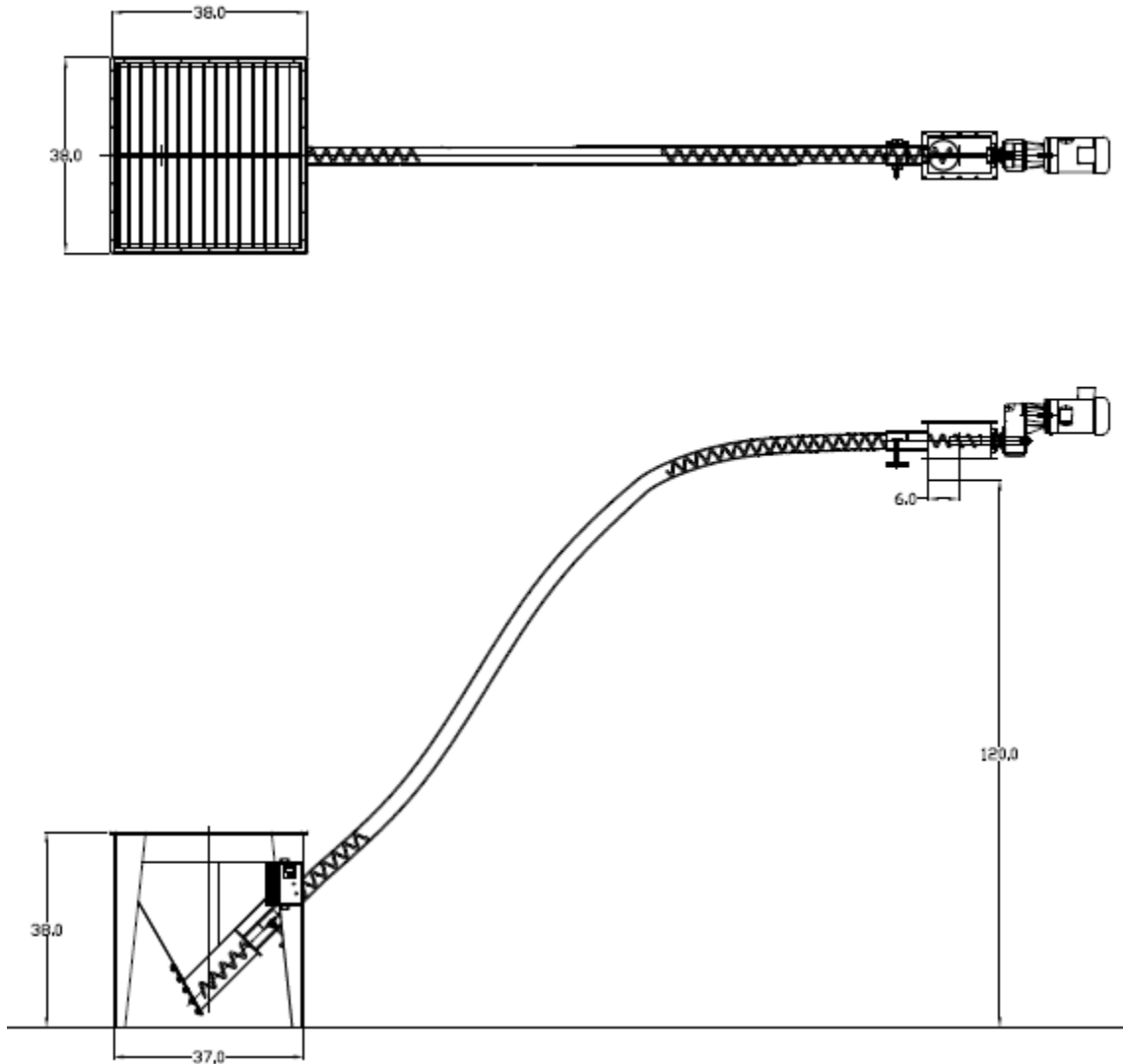

Design Specifications:

- Floor Dimensions: 38 x 60 Inches
- Height: Up to 25'
- Auger Diameter: 1-5/8" to 4"
- Feeder Motor: 3.42 K Watts
- Electrical Requirements: 208-230/480VAC,
- 3 phase, 60 Hz, 15 amp.
- Net Weight: 525 pounds
- Space Requirement: 132" x 110"
- Temperature Rating: 40° – 110° F

Accessories:

- Dust Collector
- Inlet Adapter plate for downspout entry
- Hopper Level Control
- Integrated Controls
- Mounting Base
- Transportable Mounting Base

